

Cerebro Pinout V1

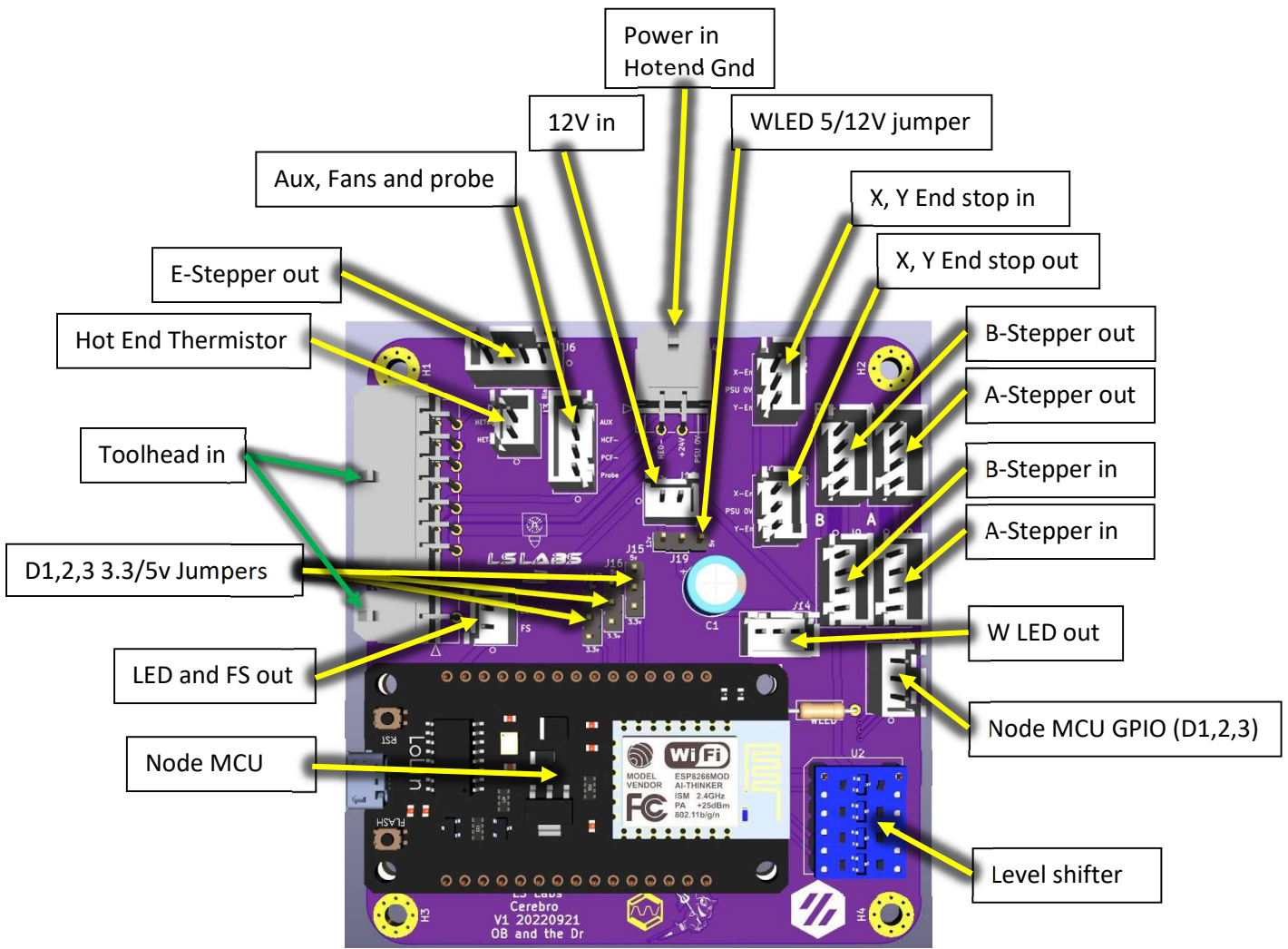

Toolhead in: Molex PN: 430450200 and PN: 430451400

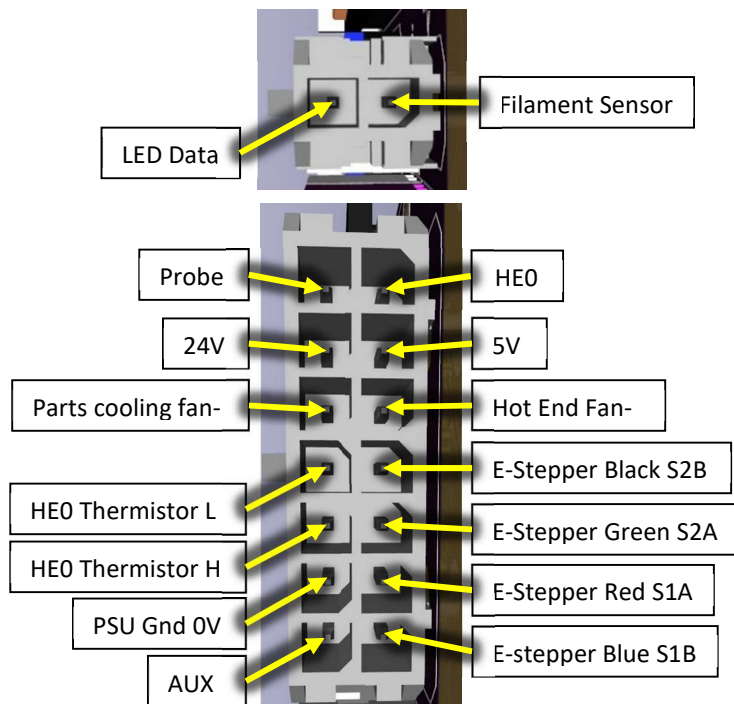

LED and FS out: JST PN: B2B-XH-A

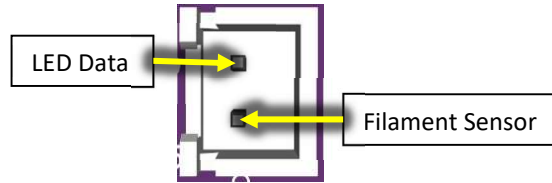

Hot End Thermistor HET: JST PN: B2B-XH-A

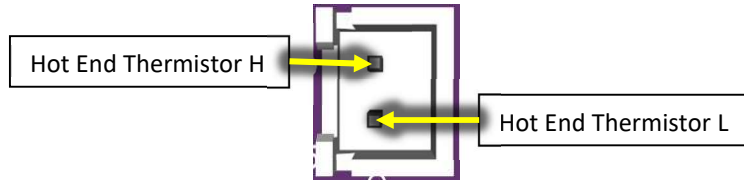

12V in: JST PN: B2B-XH-A

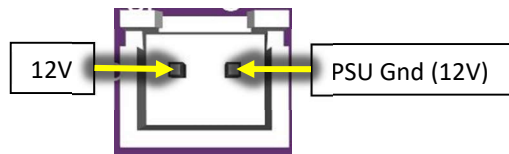

X,Y End Stop in and out: JST PN: B3B-XH-A

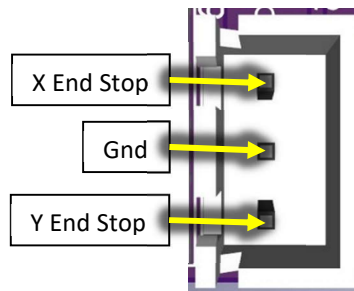

WLED out: JST PN: B3B-XH-A

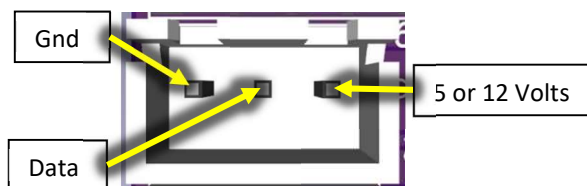

Node MCU GPIO (D1, D2, D3): JST PN: B3B-XH-A

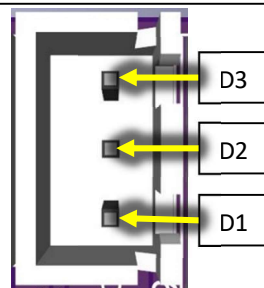

All Stepper motors JST PN: B4B-XH-A

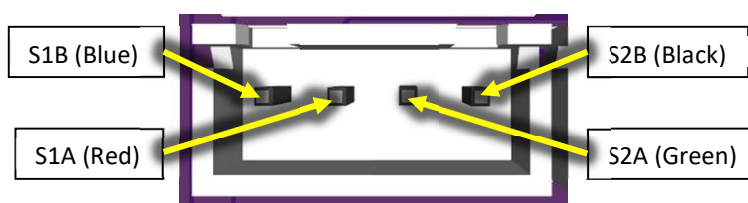

Aux, Fans and probe: JST PN: B4B-XH-A

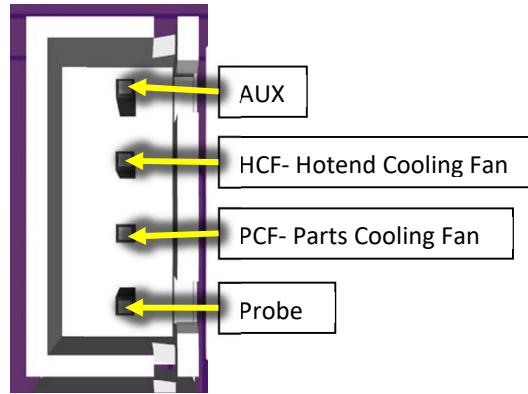

Power in Hotend Gnd: Molex PN: 430450400

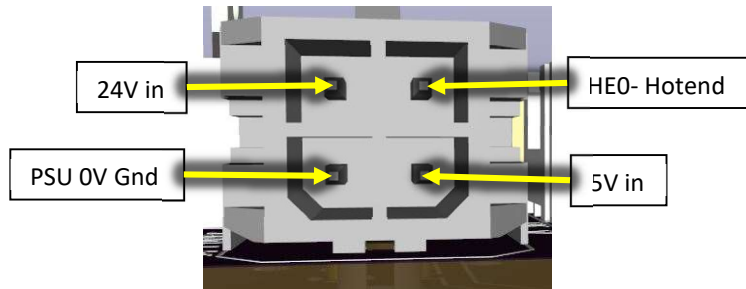

Level shifter jumper positions, selector allocation as follows: J15 - D1, J16 - D2, J17 - D3

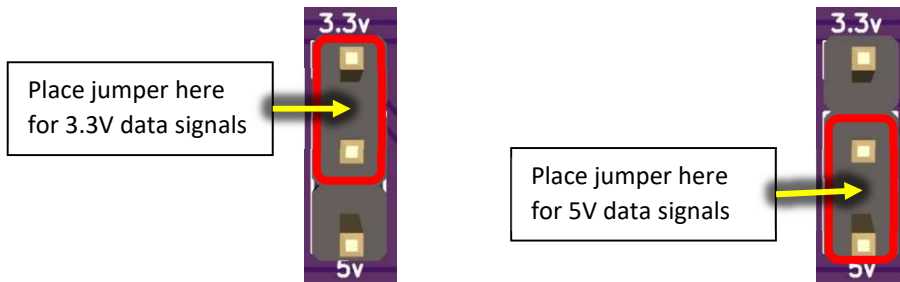

WLED 5V/12V jumper positions, to allow use with 5V and 12V LED strips
(for 12V strips an external 12V supply will be required)

